



## Application Note AN-71b

copyright  
June, 2025  
rev "b", April, 2026

web = [www.kh6htv.com](http://www.kh6htv.com) email = [kh6htv@arrl.net](mailto:kh6htv@arrl.net)

# 70 cm In-Band, DVB-T Repeater

Jim Andrews, KH6HTV

Does your local ATV group need a TV repeater? Are you debating should it be an in-band 70 cm repeater, or instead perhaps a cross-band repeater? Tight budget? Technically complex with lots of "bells & whistles" or KISS (KeeP It Simple Stupid) ? Reference [1], application note AN-23 discusses the basic principles of building a TV repeater.



*Fig. 1 This photo shows a 70cm in-band repeater built for BCARES. model 70-70R, s/n 1. All the components were assembled onto three 1U, 19", relay rack shelves. This proto-type used the 70-9B, 10 Watt, rf power amplifier. It also included a 2m FM receiver, ABOMY - Arduino DTMF decoder / relay, video monitor and +13.8Vdc power supply.*

**70cm In-Band Repeater:** A 70cm in-band DATV repeater will be more complex to make work right and costly than a 70/23cm cross-band repeater. See our application notes AN-69 & AN-70 for a description of cross-band repeaters. Why is an in-band repeater more complex? You need really great, ATV channel band-pass filters (BPF) for both the receiver and transmitter to make it function properly without serious de-sense. See app. note AN-72 [2].

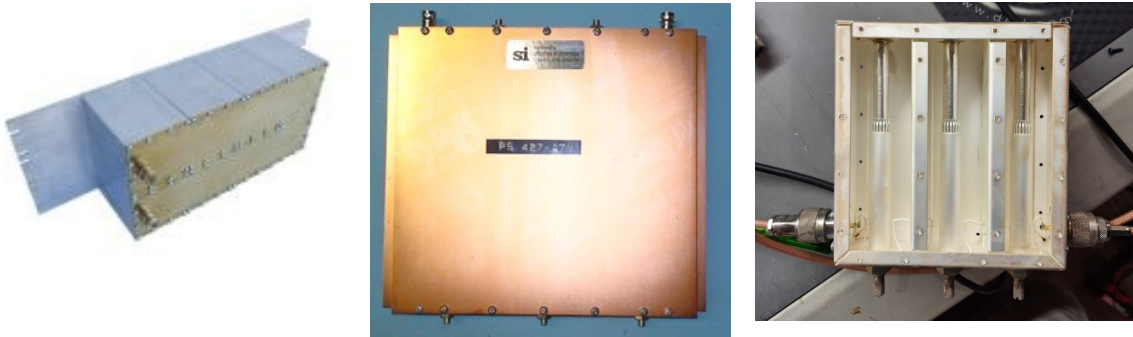

Fig. 2 Typical Band-Pass Filters used for 70 cm ATV repeaters. Left is 19" rack mount DCI filter. Middle is Spectrum International filter. Right is commercial UHF-TV broadcast filter (shown with cover removed)

These filters are not easy to come by, nor in-expensive. KH6HTV app. note AN-22b, "Inter-Digital Band-Pass Filters" [3] discusses such filters and how you might build your own. Most builders of ATV repeaters are using ATV channel filters from DCI in Canada ( [www.dcifilters.com](http://www.dcifilters.com) ). Note: DCI has been purchased recently by the Kavveri Telecom Products in Bangalore, India and communications with them now need to be addressed to [mktg@kavveritelecoms.com](mailto:mktg@kavveritelecoms.com). For 70cm, ATV, DCI offers a 6 MHz filter in either 8 or 10 pole configuration. The price tag is not inexpensive. They are currently quoting \$850 for the 8 pole filter and \$1,050 for the 10 pole. Plus USA import duties. A 70cm TV repeater will need two filters.

Another alternative is Don Nelson, N0YE. In his home shop, he has built 70cm ATV filters using the design calculator discussed in AN-22b [3]. Don's filters have more insertion loss than the DCI filters, but they are smaller and less expensive.

There are also commercial UHF-TV broadcast TV channel filters available. See Fig. 2 above. They may sometimes become available at ham radio swap fests.

**Basic 70cm Repeater:** Figure 1 is a photo of a basic 70cm DATV repeater which I recently custom built for Boulder County Amateur Radio Emergency Services (BCARES). Fig. 3 is the fundamental block diagram showing the basic elements for a KISS, basic 70cm repeater. Such a repeater could even be patched together in a few minutes in an emergency. Simply taking the HDMI output from a 70cm DVB-T receiver and patching it directly into the HDMI input of a 70cm transmitter. Attach appropriate antennas and bingo, you are on the air with a repeater. Even without the BPFs, it can be done but with severe desensing of the transmitter into the receiver [2].

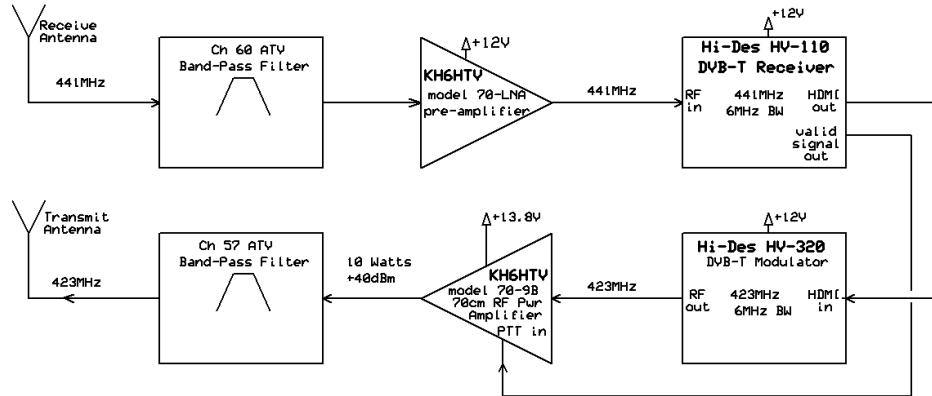

Fig. 3 Block Diagram of a basic, KISS, 70cm DVB-T ATV Repeater

**DVB-T Receiver and Modulator:** I recommend using the specified Hi-Des units, the HV-110 receiver and HV-320 modulator. For an automatic controlled repeater, it is necessary to have a "Valid Signal" detector to key on/off the transmitter. A simple modification to the HV-110 receiver provides this logic signal for the PTT line. For details on this modification, see KH6HTV app. note, AN-23 [1]. For a very simple repeater thrown together on the fly, even this is not required. Simply have an on-site control operator to manually turn on/off the transmitter.

**70cm Receiver:** A Hi-Des model HV-110 is the preferred DVB-T receiver to be used in an ATV repeater. It is quite sensitive, but a small improvement of a few dB is gained by adding a low noise pre-amplifier in front of it. The pre-amp used here is a KH6HTV model 70-LNA with 18dB gain and 0.8dB noise figure.

**RF Power Amplifier:** The amplifier shown is the KH6HTV model 70-9B which produces a 10 Watt (+40dBm) DVB-T signal. It can be driven directly by the HV-320.

**Band-Pass Filters:** The BPFs used in the prototype were commercial broadcast, three pole, UHF-TV channel filters. See Fig. 2 above. I used one 3P-BPF for the transmitter and two 3P-BPFs in cascade for the receiver.

**Performance?** So what performance can be expected. The 70cm receive sensitivity will be of the order of -90dBm or better. RF output power of about 8 Watts (+39dBm), DVB-T signal.

**DC Power Required:** The repeater is designed for +12Vdc operation (10-15V). At 12Vdc, the stand-by current draw is 1.6 Amps. When transmitting, it is about 9 Amps.

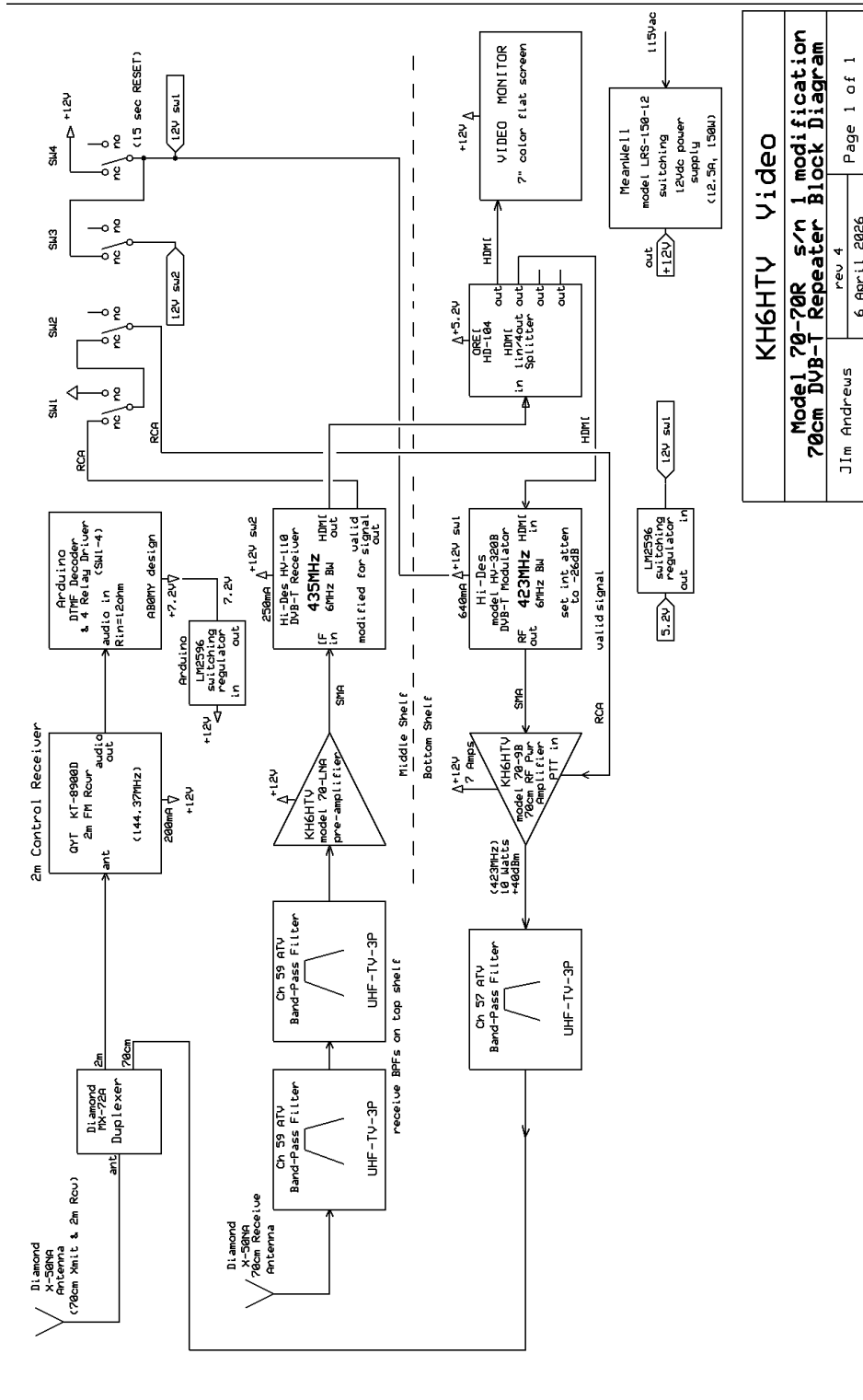

**KH6HTV Video**  
**Model 70-70R s/n 1 modification**  
**70cm DVB-T Repeater Block Diagram**  
 Jim Andrews rev 4  
 6 April 2026 Page 1 of 1

Fig. 4 Block Diagram of 70cm In-Band, DVB-T repeater built for BCARES. (70-70R, s/n 1) It is complete with 2 m control capabilities and video monitor.

**Extra Features:** As the basic "KISS" repeater, Fig.3, it will operate independent of human direct control with the automatic Valid Signal detector driving the amplifier's PTT line. For FCC control purposes, a separate control capability is required. This could be accomplished by adding a 2 meter FM receiver. This receiver then drives a DTMF touch-tone decoder / relay driver to add remote control capability. This is shown in the expanded block diagram of Fig. 4. The actual prototype shown in Fig. 1 is an example. An additional nice feature is to have a local video monitor to look at the incoming signals.

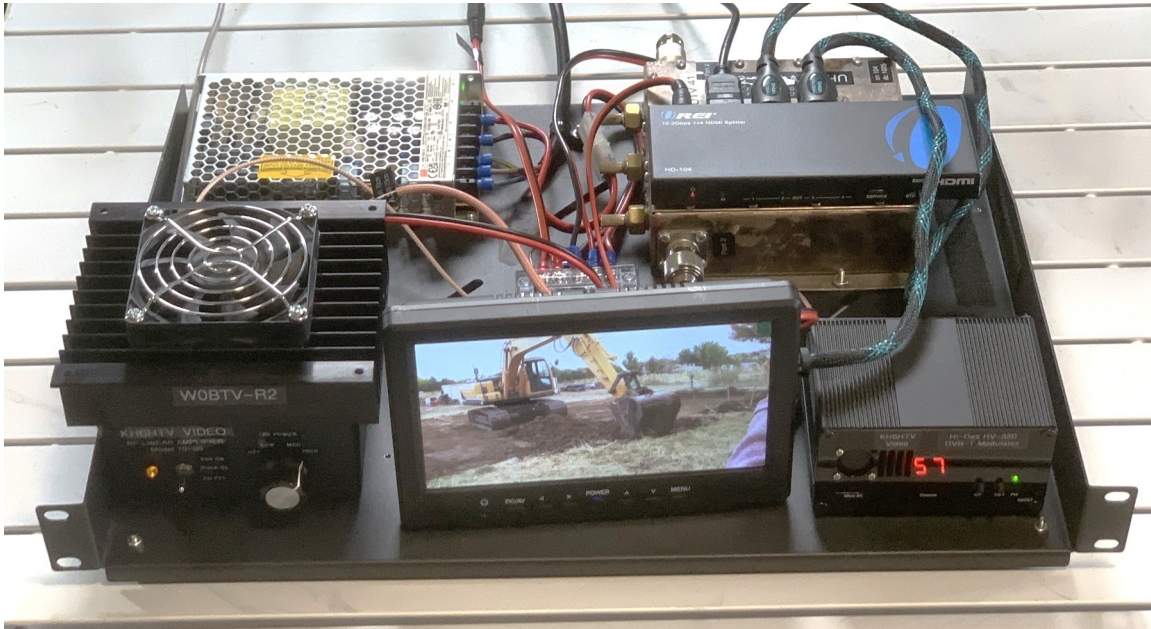

Fig. 5 1U rack tray holding the repeater's 10 Watt, 70cm DVB-T transmitter, plus video monitor and 12Vdc power supply

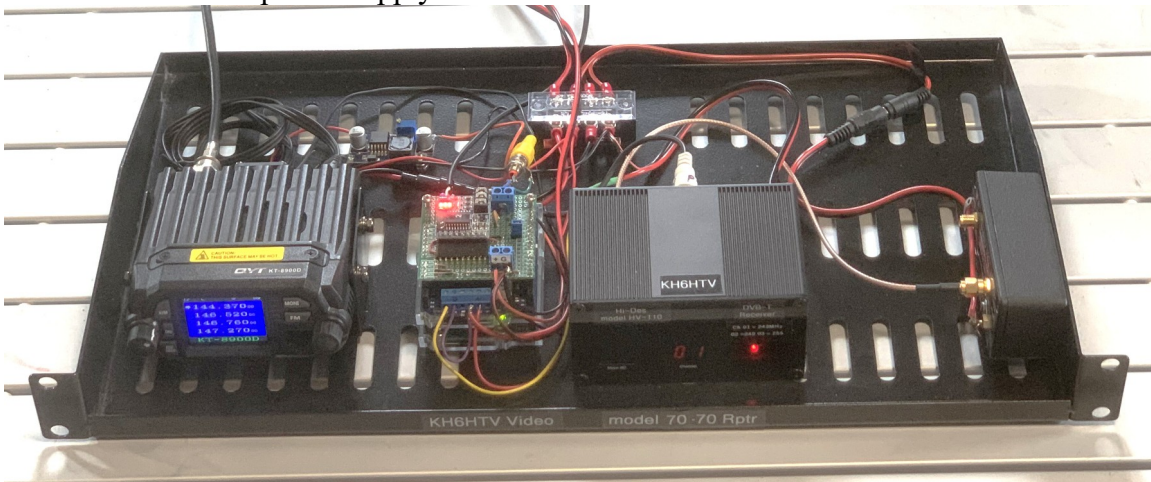

Fig. 6 1U relay rack tray holding the 2m control receiver, 70cm DVB-T receiver, pre-amp, and Arduino controller.

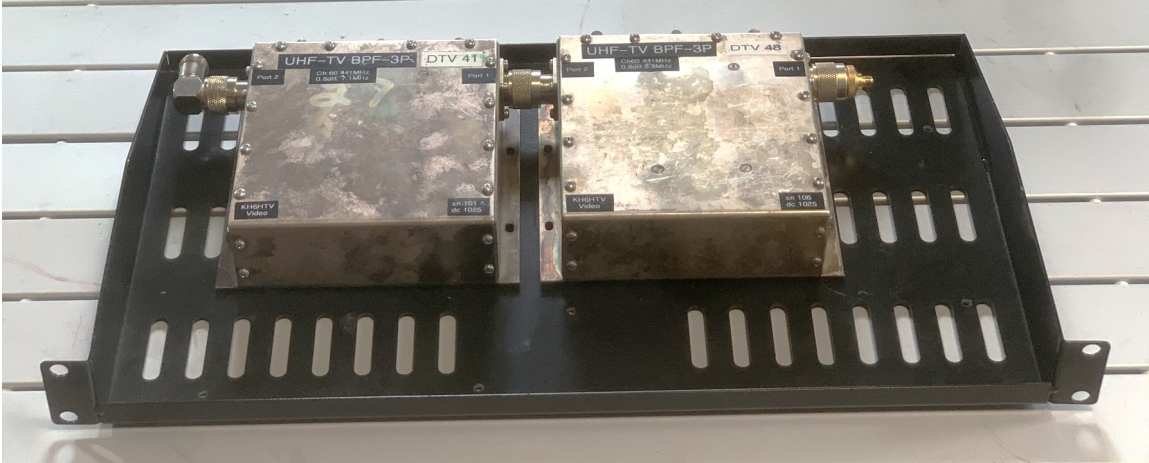

Fig. 7 1U relay rack tray holding the two UHF-TV-3P, Ch 59 receive band-pass filters

**Table 1 -- Major Components for 70cm DVB-T Repeater**

Item	Mfgr.	Model #	Description
1	Hi-Des	HV-110	DVB-T receiver
2	Hi-Des	HV-320	DVB-T modulator
3	KH6HTV	70-9B	70cm, 10W, rf linear power amplifier
4	KH6HTV	70-LNA	70cm pre-amplifier
5	various	Ch 57-BPF	70cm Band-Pass Filter, 423 MHz
6	various	Ch 60-BPF or Ch 59	70cm Band-Pass Filter, 441 MHz or 435 MHz
7	Meanwell	LRS-150-12	12Vdc, 150 W Power Supply
8	AB0MY	TT-4relay	Arduino with custom touch-tone (DTMF) decoder & 4 relays + programming as desired
9	QYT	KT-8900D	2m FM mobile transceiver ( <i>only use the receiver</i> )
10	Amazon	various	Video Monitor, 7" flat color screen, HDMI input, +12Vdc
11	OREI	HD-104	HDMI A/V splitter -- 1 in, 4 out, +5Vdc
12	Diamond	MX-72A	2 m / 70 cm duplexer
13	Diamond	X-50	2 m / 70 cm Antenna, (2) required

**Repeater Remote Control:** To meet FCC requirements for an unattended repeater an alternate means of controlling or disabling the repeater is required. For the W0BTv, NCAR, ATV repeater this is done using touch-tones (DTMF) on a 2 meter control frequency. The same is used for this 70cm repeater. In years past, we have used a DTMF decoder / relay board from Intuitive Circuits. However, we no longer recommend them as we have had several failures. Their product dates back to the 1990s. We also

had issues buying similar ones from Amazon. So recently Bill, AB0MY, has designed a new decoder using as it's basis an Arduino micro-controller. So we now recommend Bill's unit. It also has the advantage that Bill can custom program it to the user's specific control functions. For the prototype, the AB0MY DTMF decoder works as shown in Table II.

**Table II --- Repeater Remote Control Functions**

Function 3	Description	( * )	( # ) normal state
1	Transmitter ON	ON	xmitter enabled
2	Transmitter Disabled	disabled	xmitter enabled
3	Color Bar Beacon	receiver OFF	receiver ON
4	Digital Reset	Reset (15 sec)	-- NA --

**Repeater ID:** The FCC requires that all transmissions be identified, at least once every 10 minutes. For this repeater, we ID it continuously. As part of the A/V data stream there is also sent out a Metadata file with info about how the data is encoded. Included in this meta file is the transmitter's call sign. This is pre-programmed into the HV-320 modulator. The HV-110 receiver decodes the call sign of valid incoming DVB-T signals. The HV-110 receiver is set up to provide a permanent On Screen Display (OSD) of the call sign of the incoming signal along with the received signal strength in dBm and the signal to noise ratio in dB. This in then rebroadcast on the outgoing signal.

**Antennas:** This repeater is intended for use with either two or three separate antennas. One for 70cm receive, one for 70cm transmit and one for 2 meter control. Or alternately, as shown in Fig. 4, a dual-band 2m/70cm antenna could be used for the TV transmit and 2m control receive antenna. This requires the addition of a 2m/70cm duplexer. The selection of antennas is open to the user depending upon the coverage area desired, etc. There is a wide choice of antennas possible. Suggested reading is our application note, AN-67 "Comparison Tests of Various 70 & 23cm Antennas for ATV" [4]. Our favorite low cost 70cm base station antenna is the Diamond X-50. For a more rugged, commercial grade antenna, the Andrew DB-411, four element co-linear is recommended. Low loss coaxial cable, such as LMR-400 should be used as the feed-lines. The physical separation between the 70cm transmit and receive antennas should be to give at least -40dB or more isolation between them.

**Final Test of Sensitivity:** Fig. 8 below shows how to measure the sensitivity of a repeater's receiver both on the test bench and also in a real world environment. A directional coupler is used to inject a known DVB-T test signal into the antenna port of the repeater.

Most DTV receivers tend to retain the last valid image decoded and display it on the screen. Thus if only a still image is transmitted as a test signal, it is difficult to know when the receiver is actually receiving properly -- or --- one is simply seeing a "Freeze-

Frame". Thus it is important to use an A/V video source containing a lot of live motion and audio sounds. Playing back a DVD movie is ideal.

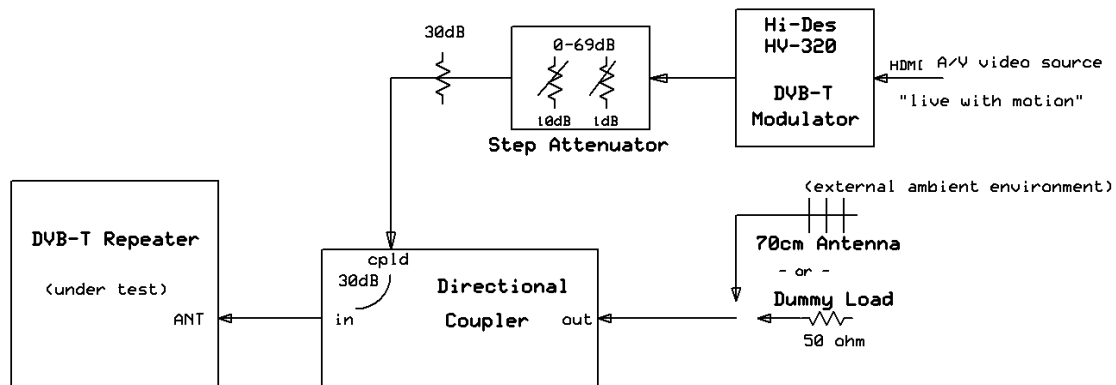

Fig. 8 Test Set for measuring the sensitivity of a DVB-T receiver

The first step is to set the modulator to a known RF output power level in dBm. Then knowing the amount of added attenuation in dB, it is straight forward to know the amount of rf power injected into the receiver under test.  $P_{in} = P(\text{mod}) - \text{Attenuators} - \text{Directional Coupler}$ .

Digital Receiver's Sensitivity is defined as the Digital Threshold which is the minimum rf signal level which results in a perfect P5 / Q5 picture & audio with no defects such as freeze framing. When using the Hi-Des HV-110 receiver a good visual indicator is also it's front panel red/green Valid Signal LED. It glows solid red with no signal. It glows solid green with P5/Q5 signal. It will flicker red - green with a weak signal just below digital threshold. Record the weakest signal level (in dBm) at which you get solid green. Also record the resultant signal to noise ratio S/N in dB.

**Final Field Test:** Using the above technique to measure receiver sensitivity the prototype 70cm repeater was tested. I used two Diamond X-50 antennas for transmit and receive. They were mounted on top of 10 ft. masts and spaced horizontally 20 ft. apart. On the test bench with a 50 ohm dummy load in place of the receive antenna, the 70cm sensitivity was found to be -96dBm (note: measured with "aggressive" DVB-T signal [720p, 3.5Mbps, H.264, 6 MHz BW, QPSK, 1/2 code, 1/16 guard]).

For the second test, in a real world environment, the dummy load was then removed and replaced by the Diamond X-50 receive antenna mounted on an antenna mast outdoors. In this case, the repeater's receiver was going to be exposed to what ever other rf is flying around, other ham signals, FM repeaters, broad-band noise sources, etc. For the test at the qth of KH6HTV, the rf background degraded the sensitivity to about -92dBm. Your actual sensitivity will vary depending upon your local RFI environment.

## Appendix I: Band-Pass Filters

s/n 1 Repeater:      input = Ch 59, 435 MHz      output = Ch 57, 423 MHz  
 for 6 MHz BW DVB-T    in & out

For the proto-type model 70-70R, s/n 1, repeater, I used a total of three UHF-TV-BPF-3P, three pole filters. See the photo on the right in Fig. 2 and Fig. 7. One filter was tuned to 423 MHz for the transmitter. A cascade of two filters was tuned to 435 MHz for the receiver. The following figures show the resultant swept frequency responses.

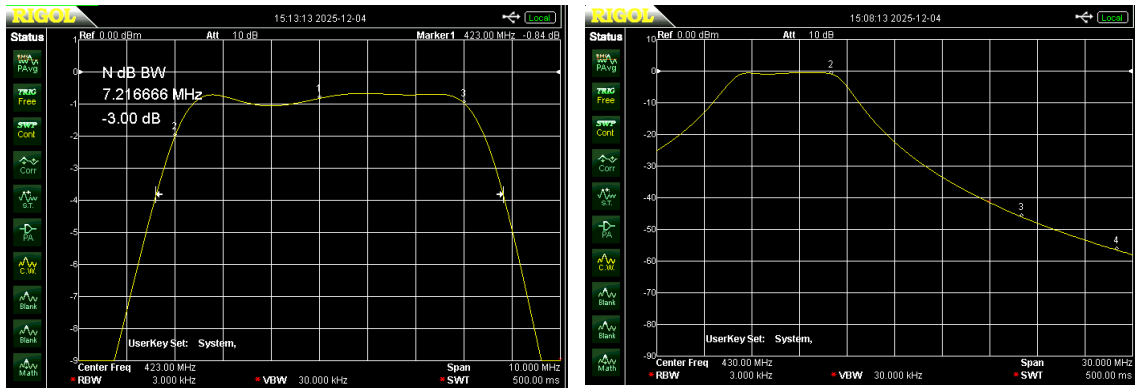

Fig. 9 S21 swept frequency response for Ch 57, transmitter band-pass filter. One UHF-TV-3P filter. left pass-band response, center freq. = 423MHz, 1dB/div & 1MHz/div. Insertion loss = -0.9dB, -3dB BW = 7.2 MHz. right stop-band response, center freq = 430 MHz, 10dB/div & 3MHz/div

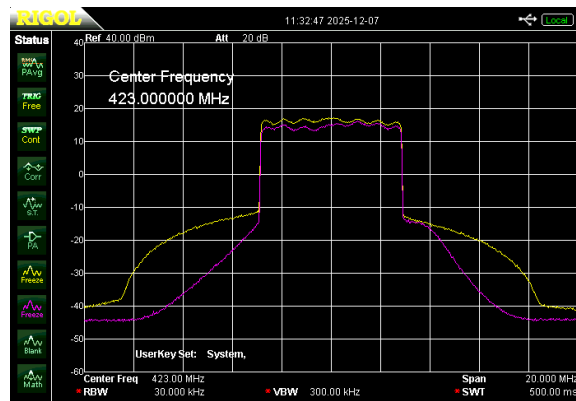

Fig. 10 Transmitter Output Spectrum -- yellow trace is output from final rf power amplifier. magenta trace is after passing through the 3 pole BPF. center freq. = 423MHz, 10dB/div & 2 MHz/div. RF power output = +39dBm = 8 Watts (avg)

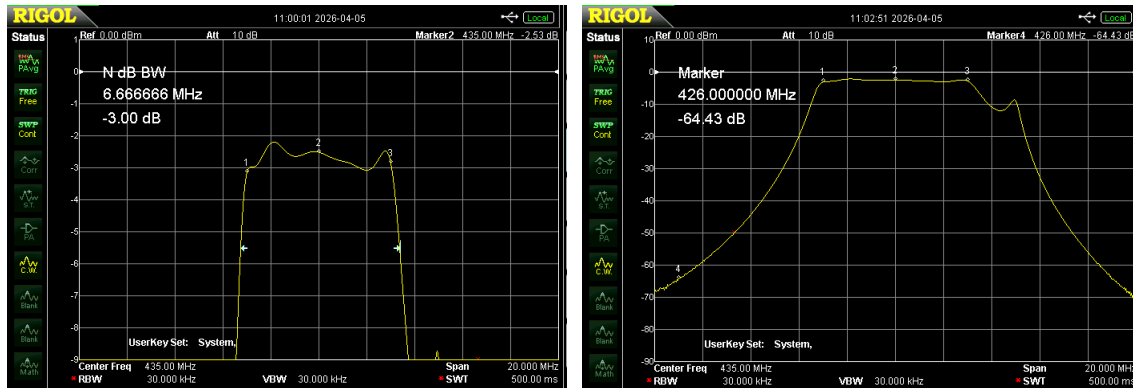

Fig. 11 Receiver's Band-Pass Filter S21 frequency response. center freq. = 435 MHz, left is pass-band response 1dB/div & 2 MHz/div right is stop-band response 10dB/div & 2 MHz/div. Insertion loss = -2.5dB -3dB BW = 6.7 MHz

## REFERENCES:

1. "DVB-T Television Repeater", Jim Andrews, KH6HTV Video application note, AN-23h, June 2015, rev."h" March, 2025, 12 pages
2. "Filtering Requirements Design for a 70cm DVB-T Repeater" Jim Andrews, KH6HTV Video application note, AN-72, Oct. 2025 10 pages
3. "Inter-Digital Band-Pass Filters" Jim Andrews, KH6HTV Video application note, AN-22b, July 2015 8 pages
4. "Comparison Tests of Various 70 & 23 cm Antennas for ATV", Jim Andrews, KH6HTV Video application note, AN-67, Feb. 2023, 15 pages